

# WEIGH-TRONIX

- Legal for trade, Class III/IIIL 10,000d
- Stainless steel NEMA 4X enclosure
- Bright, easy-to-read, .8 inch LED display
- Numeric keypad
- Three programmable units of measure
- Three setpoint outputs, options for up to ten
- Seven logic level inputs
- Built-in serial port
- Ten tare memory
- Built-in time and date, battery protected
- Harmonizer™ filtering software
- Front panel configuration
- Sixty times per second A to D conversion
- Display rate - Ten times per second
- Five point linearization
- Battery backed-up RAM
- Options for system expansion



## WI-127 Indicator

# Just one instrument – with so much capacity for work

*The WI-127 Indicator from Weigh-Tronix is proving to be the instrument of choice in thousands of industrial settings. It brings a full spectrum of standard features and a flexible options package which make it easily adaptable to almost any application. Seldom will you find the opportunity to purchase a single instrument with this much power and functionality.*



## One instrument, multiple tasks

One way to gauge the value of a weighing instrument is to measure its ability to grow and adapt to new processes. The WI-127 Indicator switches easily from job to job. The WI-127's operations mode lets you view or change the parameters for all its normal weighing operations: push-button tare; keypad tare entry; one to ten tare registers; setpoint registers; checkweighing values

for target weight, over and under; identification number, time and date. Its simple setup allows you to choose any capacity you need.

Use it with a simple floor scale for gross-tare-net weighing. Operators can enter a tare value any of three ways. They can use a container and do a simple push-button tare. They can use the keypad to enter a known tare value. They can select one of the ten

tare registers from the instrument's memory bank.

The WI-127's NEMA 4X stainless steel enclosure protects it in harsh industrial settings. It is immune to water, dust, dirt, and changes in temperature.

Its large, bright display is easy to read from a distance. Its lighted digits are visible even in low light environments.

## Simple batching systems

In order for a weighing instrument to be successful as a batching indicator it must have two critical characteristics. First, it must be capable of overcoming the inaccuracies caused by vibration from wind, traffic, conveyors, augers, loading and unloading of ingredients. And second, it must be expandable to operate a full system.

## Noise and vibration filtering

The WI-127 features the Harmonizer™ fully adjustable filtering system which corrects for environmental noise and vibration.

Harmonizer offers three types of application-specific filtering: multiple levels of filtering for vibration frequency, adjustment for amplitude, and finally a selectable "threshold," or a level of weight change at which the dampening is disabled. This speeds the weighing process; the scale reads quickly any weight changes that exceed the selected threshold value.

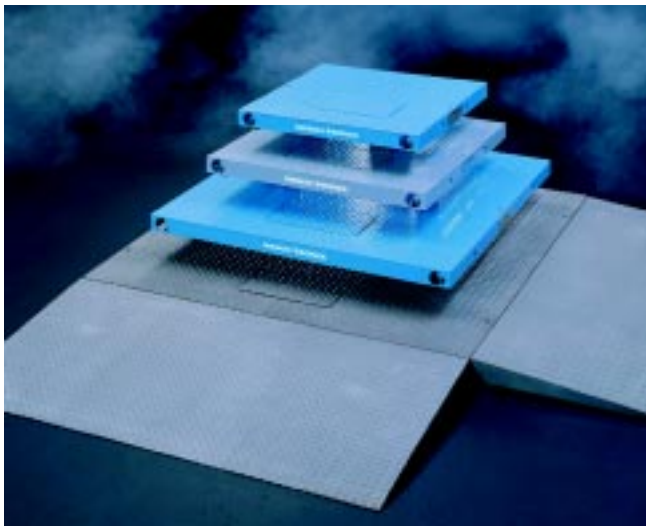

## Input/output opportunities

To fit effectively into a system, such as a batching or checkweighing operation, scale instrumentation must have the capacity to work with multiple components. That's why the WI-127's designers gave it such flexible input/output capability. It has three standard setpoint outputs for controlling peripheral equipment. It has options for a total of ten outputs.



The WI-127's built-in serial port, which enables you to send scale data to a printer, computer or programmable controller, can be configured to RS-232, RS-422/485 or 20mA current loop.

Operators can use its logic level inputs to provide remote operation of the Zero, Print, Tare, Select and Unit keys in system applications.

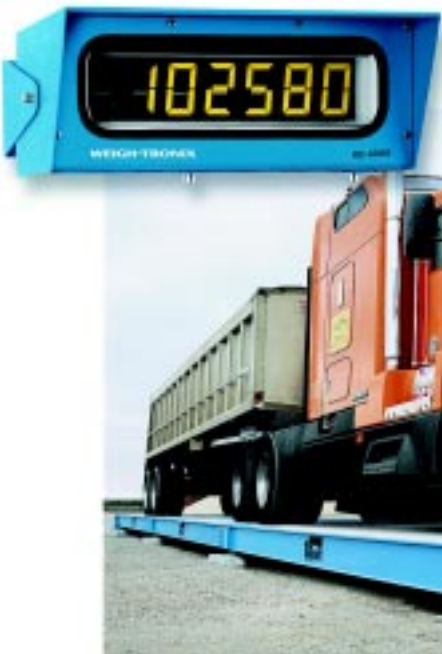

## In-motion weighing

Two things determine the success of the WI-127 Indicator as an instrument for in-motion weighing. First is the Harmonizer™ filtering system which adjusts to correct for the noise and vibration that is a natural part of most in-motion weighing applications such as monorail and conveyor weighing. The second reason for its success as an in-motion weighing instrument is its speed. As an in-motion weigher, the WI-127 uses two inputs that signal when an object enters and exits the weighing zone. The instrument's one million count analog to digital converter samples at 60 times per second. The indicator averages the weight samples it takes while an object is between the two inputs and then feeds each resulting weight value to a printer or to a data collection device such as a PC.



The WI-127 In-motion Indicator easily expands to a system. For example, you can employ its three standard outputs to operate peripheral devices for a checkweighing system.

## Inbound/outbound weighing

The WI-127 Indicator, which supports up to twelve 350-ohm load sensors, is proving its value daily in truck scale applications. It will be an equally valuable tool for any system that needs automatic calculation of net weight followed by serial transmission of the net value to a printer, computer, or remote display.

The WI-127 Inbound/Outbound lets you select from two methods of net weighing. Operators can get a tare weight by a live weighing of an empty container or vehicle. Or they can use the keypad to enter a known tare weight. Operators can store the tare values in the instrument's 300 memory channels. During later weighments the indicator will use the stored tare to automatically

calculate the net value and transmit it to computer, printer, or remote display.

In addition, the instrument accumulates and reports scale data. The WI-127 automatically tracks the number of transactions and accumulates the totals for each tare register. After any series of weighments, operators can request a printed report from the WI-127 Indicator. The inbound/outbound report prints the time and date, all truck or container numbers in the database and their corresponding net totals.

## Specifications

### Power requirements:

115 Volts AC, +10% to -15% @ 0.3Amp maximum  
230 Volts AC, +10% to -15% @ 0.15 Amp maximum  
50/60 Hz

### Excitation: 10 Volts DC

Supports up to twelve 350-ohm weight sensors

### Operational keys:

Five yellow standard keys: Zero, Tare, Print, Units, Select  
Three function keys: F1, F2, F3  
Numeric keys: 0-9

### Operational annunciators:

Gross, Tare, Net, Print, Zero, Motion  
Under, Accept, Over, Cutoff, ID,  
Three units of measure

**Display:** Eight-digit, seven-segment, 0.8-inch high LED

**Display rate:** Selectable (1, 2, 5, 10)

**Analog to digital conversion rate:** 60 times per second

### Unit of measure:

Three, independently programmable:  
Pounds, kilograms, grams, ounces, ton, tonne, custom,  
Off

### Capacity selections:

999,999 with decimal located from zero to five places

### Incremental selections:

Multiples and sub-multiples of 1, 2, 5

### Programmable selections:

Zero range, motion detection,  
automatic zero tracking, five-point linearization.

### Time and date / RAM:

Battery backed up real time clock and RAM are standard

**Internal resolution:** 6,291,456 counts per mV/V per sec.

### Harmonizer™ digital filtering:

Fully programmable to ignore noise and vibration

### Standard inputs:

Seven configurable logic level inputs for functions such  
as tare, print, zero, units, etc.

### Standard outputs:

Three cutoff outputs, open collector design  
Relay power supply, 24 VDC at 150mA  
5 VDC at 200 mA for scanner power source  
Bidirectional serial port (RS-232 or RS-422/485 or  
20mA current loop)

### Serial Command Inputs:

Programmable serial response to ASCII character input

### Self diagnostics:

Display, keys, inputs, outputs, serial port,  
A to D converter, voltages

**Circuitry protection:** RFI, EMI, and ESD protection

### Options:

Two additional serial ports  
BCD parallel  
16 outputs & 8 inputs  
Analog output  
0-5, 0-10 volts  
1-5, 4-20, 10-50 mA

### Operating temperature:

-40 to 140° F (-40 to 60° C)  
100% relative humidity including washdown

**Enclosure:** NEMA 4X stainless steel enclosure

### Dimensions:

12" W x 8" H x 4" D (without mounting bracket)  
12.3" W x 11.0" H x 5.3" D (with mounting bracket)

**Weight:** 12.5 lb, 5.7 kg

### Agencies:

NTEP Class III/IIIL:10,000 divisions  
Certificate of Conformance #96-140.A1  
Canadian Weights and Measures #AM-5167  
FCC Class A  
CSA, CUL, UL

**Warranty:** 2 year

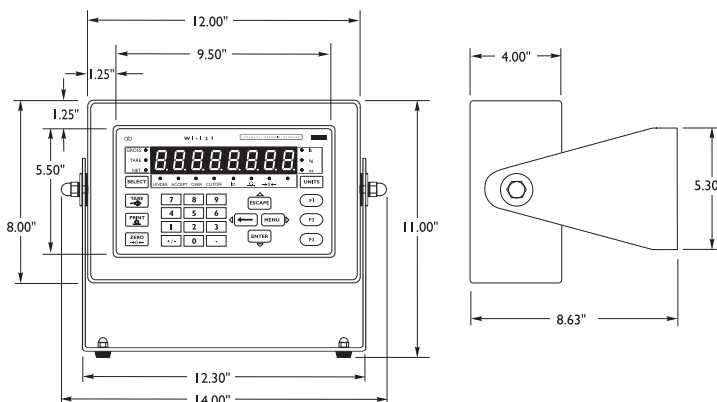

### Weigh-Tronix

1000 Armstrong Dr.  
Fairmont, MN 56031 USA  
Telephone: 507-238-4461  
Facsimile: 507-238-4195  
e-mail: industrial@weigh-tronix.com  
www.weigh-tronix.com

### Weigh-Tronix Canada, ULC

217 Brunswick Blvd.  
Pointe Claire, QC H9R 4R7 Canada  
Telephone: 514-695-0380  
Facsimile: 514-695-6820

# WEIGH-TRONIX

Weighing Products & Systems

# WEIGH-TRONIX

## WI-127 Indicator Outline Dimensions (inches)

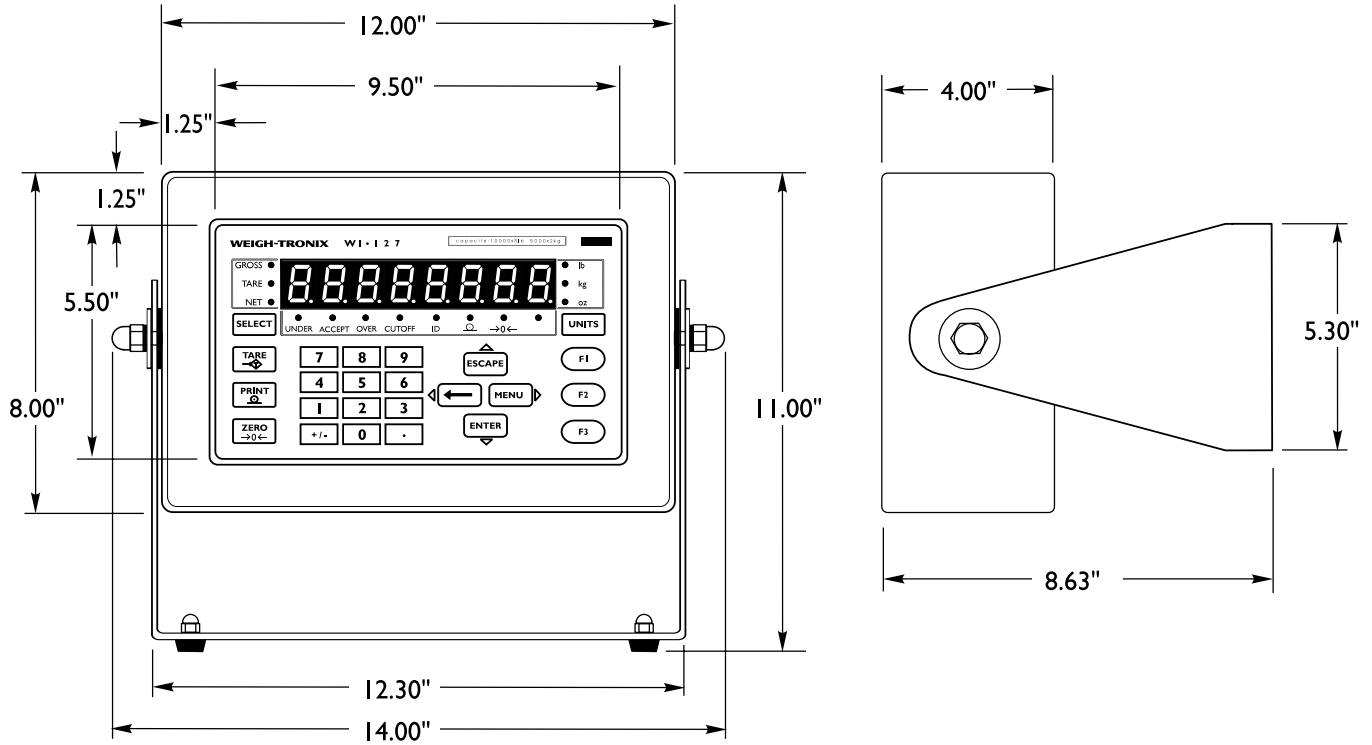

Front view - desk top stand

Side view - wall mount

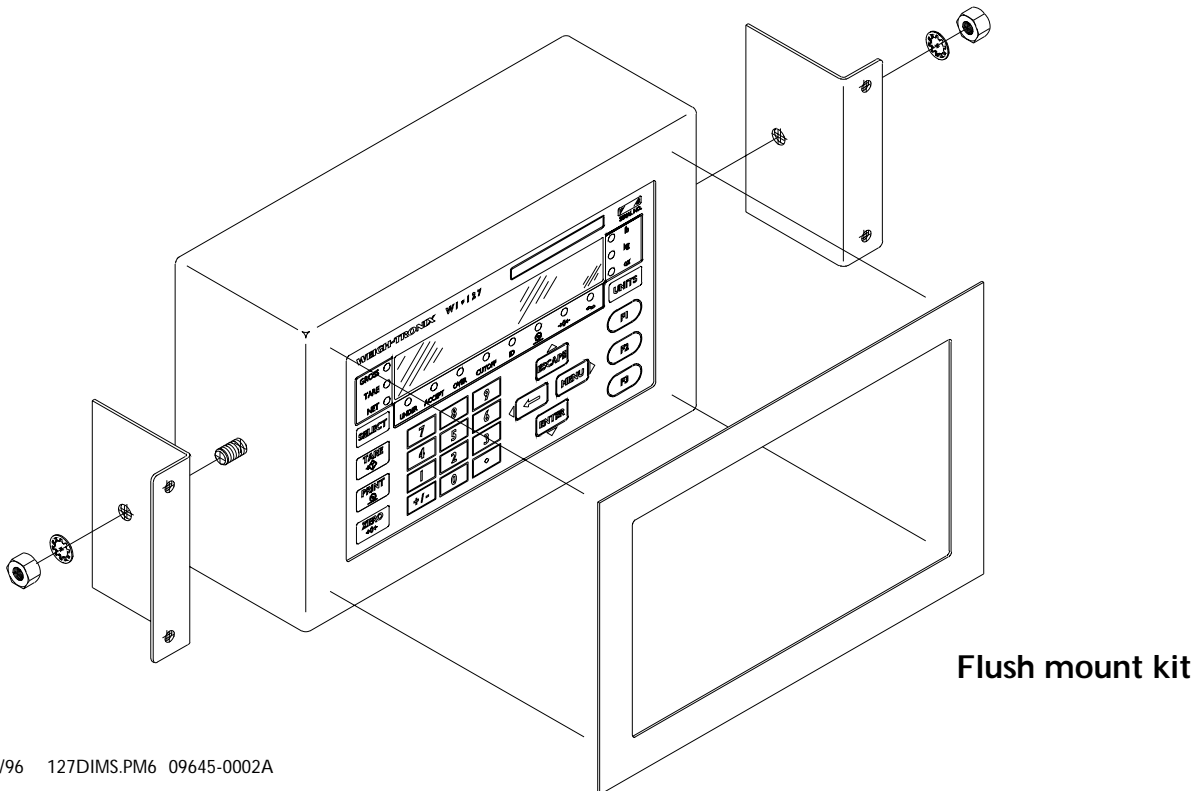

Flush mount kit